

**VOLVO  
PENTA**

# DESIGNED FOR PRODUCTIVITY

High-performance propulsion





An aerial photograph of an offshore wind farm. Several white wind turbines are visible, extending from the foreground into the distance. A service vessel is moving through the water, leaving a white wake. The water is a deep blue-grey color. The sky is not visible, suggesting a high-angle shot.

# WHEN TIME IS TIGHT

When time is tight professional marine operators must be able to trust their equipment. For more than 100 years, we have been developing, designing, manufacturing and servicing power solutions that meet all the demands of heavy-duty applications in marine environments. We are proud that operators in a variety of areas and businesses, all over the world, put their trust in our ability to provide outstanding power for marine professionals.



# An inclusive offer to marine professionals

A service vessel on its way to repair a malfunctioning wind power station, a marine ambulance rescue operation racing to assist at the scene of an accident, or a coast guard vessel intercepting a suspected smuggler – in almost every marine profession, time is the most critical factor. It's often the difference between a successful operation and a failure.

Through long-lasting cooperation with operators, designers, manufacturers and classification societies, we know your business from within. But we also know your desire to get the best out of leading-edge technology, drive a efficient operation and meet environmental demands.

## Long-term partnership

Our core products are the Volvo Penta engines, but our offer to you goes far beyond that. Innovative drive systems and accessories, outstanding fuel efficiency and reliability, and a global service dealer network bring about a partnership for performance and productivity in the long term.

## Sustainable development

Economic growth and environmentally sustainable development are the major challenges of our time. Each year, Volvo Penta devotes numerous resources to developing products that meet our customers' demands for reliable high performance, as well as minimal environmental impact. Being environmentally aware – and acting accordingly – is not only a matter of conscience. Today, it's a competitive edge and, more often, also a legal demand. We will continue to work in close cooperation with our partners and customers and remain at the forefront of technological and environmental development – today, tomorrow and in the future. Because time is tight, also in an environmental perspective.



As part of the Volvo Group, we proudly uphold the Volvo heritage and benefit from the group's tremendous expertise and technology resources. Our leading-edge automotive technology, adapted for marine environments, has given us a strong position in the market.

# A VOLVO GROUP COMPANY

# KEEPING UPTIME HIGH – AND TOTAL COST OF OWNERSHIP LOW



With more than 100 years of experience working with marine professionals, we have the heritage and knowledge necessary to support your engine throughout its entire lifecycle.

When it comes to propulsion in marine commercial applications, the key to a profitable operation is minimizing cost and maximizing engine uptime. Our robust Volvo Penta engines are renowned for their high performance and reliability. This makes them perfect for demanding marine propulsion applications – and provides the best conditions for maximal uptime.

#### **Predictability**

Predictability increases uptime. Volvo Penta service agreements can be tailored to your operating needs and budget to include anything from regular inspections to a comprehensive service and maintenance program that includes preventive repairs. The service agreement is between you and your Volvo Penta dealer, and helps you maximize uptime, lower total cost of ownership and improve cost control.

#### **Fuel efficiency**

Fuel consumption accounts for the largest portion of your total operational cost. That is one reason why marine operators all over the world have selected the extremely fuel-efficient Volvo Penta power systems.

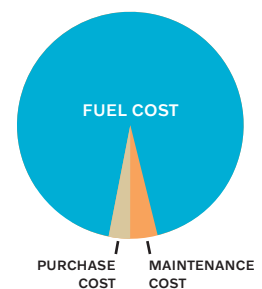



# Ensuring your business is running at full capacity

Maximum uptime always starts with premium product quality. Well-designed, robust, high-performance engines and drive systems. The materials, the excellence in engineering and the innovativeness. With Volvo Penta genuine service and parts, you ensure performance, longevity and optimal fuel efficiency for your installation.

## Volvo Penta global service and support

- Global marine commercial dealer network
- World class parts distribution network
- Volvo Penta Action Service
- Exchange Components
- Repair & Overhaul kits
- Service Agreements
- Volvo Penta Oil Analysis
- Extended Coverage
- Quickline repowering service

## Whenever, wherever we are there to support

### Global dealer network, local expertise

The Volvo Penta marine commercial dealer network covers 130 countries, with 700 authorized dealers worldwide. They comply with our marine commercial dealer operating standard, which is designed to ensure consistently high-quality service and support. This includes 24/7 accessibility, parts availability, advanced diagnostics, and technical competence to secure the local expertise necessary to keep your business going.

Find your nearest Volvo Penta dealer at [volvopenta.com](http://volvopenta.com) or download our dealer locator app.

### World class parts distribution network

As part of the Volvo Group, we benefit from one of the world's most efficient parts distribution networks in the industry – the Volvo Group Logistics Services. Working from 17 key locations around the world, 24/7, to ensure you get the right parts at the right place at the right time.

### On call 24/7/365 in 28 languages

Our global dealer network – your first line of contact – is backed up by Volvo Penta Action Service, a phone based breakdown and support service providing assistance 24 hours a day, every day of the year.

- Global support 24/7
- 28 languages
- A dedicated operator stays with your case until the problem is resolved



Check out the Volvo Penta global service and support film:



# A stable platform – this is EVC at work



By fully integrating a boat's engines, electronics and unique optional functions to one platform, the type-approved Volvo Penta EVC (Electronic Vessel Control) provides outstanding performance and safety. With all information collected in one CAN-bus backbone, the amount of wiring and number of connectors is radically reduced, resulting in higher reliability and easier installation.



## Easy to use and expand

With the EVC, you can easily master and monitor all functions through the controls and displays. The EVC provides full monitoring, protection and diagnostics for both engine and transmission – as well as increased control. All updates are simple to perform, and the broad range of smart accessories and new functions are easy to install.

## EVC for optimal performance

The unique Volvo Penta EVC functions are easily mastered and monitored through the controls and displays.

## Keep your boat still and steady

Hold your boat's position and heading practically still and steady with the Dynamic Positioning System – for safe maneuvering when waiting to refuel or preparing for offloading of equipment and personnel at an offshore site.

## Precise and active maneuvering

Use Joystick Driving to steer comfortably – with precision – at all speeds, just by pushing and rotating the joystick. The EVC system is easily interfaced with a number of autopilots.

## Easy, high-precision docking

With Joystick Docking, every docking maneuver is rapid and exact. Just move the joystick in any direction and your boat will follow.

## Perfect trim – perfect balance

The robust interceptor trim system, IS, provides optimal boat attitude in all conditions and increased visibility during acceleration and in sharp turns.

## At your service

The 7" color display shows all available information the way you want it: digital or analogue readers, tailored or standard view, etc. for up to three engines.





## EVC options

	Volvo Penta IPS	Sterndrive	Inboard
Joystick Docking	●	● (1)	● (1)
Joystick Driving	●	● (1)	● (1)
Dynamic Positioning System*	●	● (1)	
Autopilot**	●	● (1)	● (1)
Interceptor System	●	●	●
Powertrim Assistant		●	
Glass Cockpit*	●	●	●
Trip computer	●	●	●
Cruise control	●	●	●
Single-lever mode	●	●	●
Low-speed mode	●	●	●

1) Requires factory-installed electronic steering

\* Not covered by type approval

\*\* Not wheel marked

Not all functions are available for type-approved installations. Availability depends on EVC generation. For detailed information, please contact Volvo Penta.

## Simple and safe

To make Volvo Penta EVC as safe and reliable as possible, we have based it on a unique and simple concept:

- ONE system, including all engines and all functions.
- ONE company responsible for design and testing.
- ONE point of contact for the whole system.
- ONE method of installation for manufacturers.
- ONE tool for service technicians.
- ONE interface for operators.





## IPS application chart

The figures correspond to the approximate crankshaft power (hp) needed from an equivalent inboard shaft installation with a planing hull.

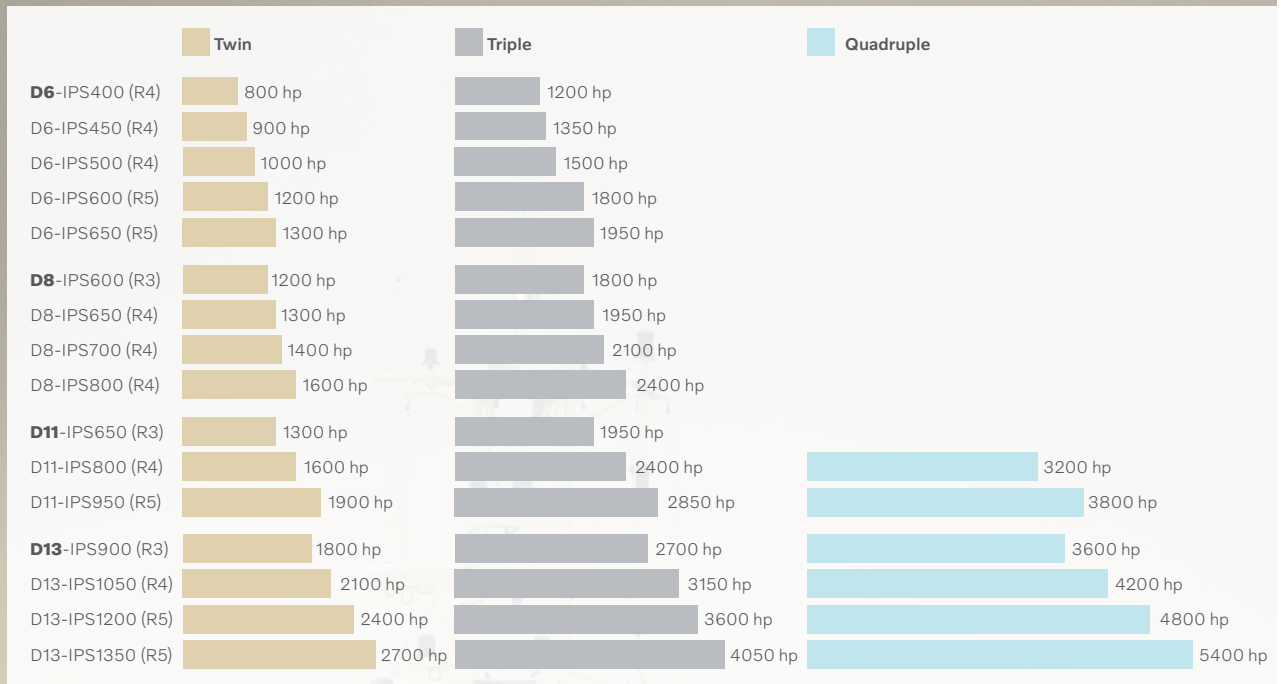



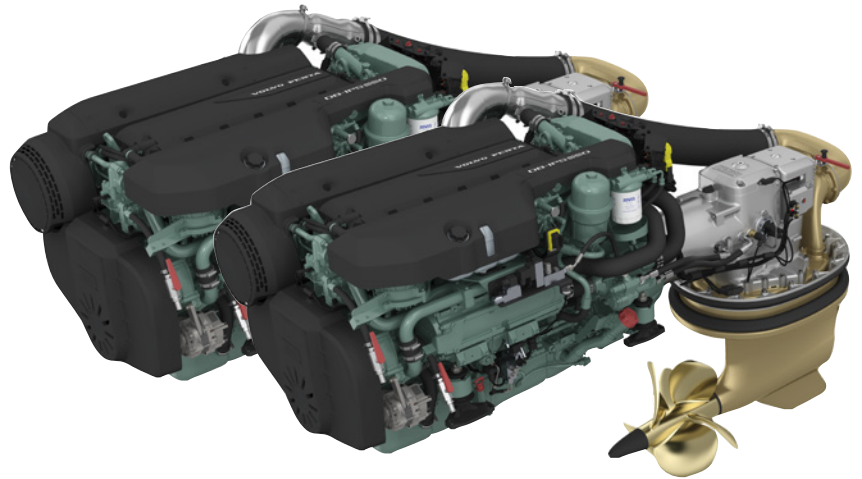

# High-performing in every aspect

The unique, type-approved Volvo Penta IPS system is well proven by operators all over the world who value performance, maneuverability, and on-board comfort. The key to these exceptional qualities is the forward-facing, twin counter-rotating propellers and individually steerable pods under the hull.

## Improve your working environment

Significantly reduced vibration and noise levels increase on-board comfort and make for better working conditions.

## Save time with active maneuvering

All IPS vessels offer effortless and precise maneuvering. This makes docking procedures time-efficient and cuts turnaround time.

## Developed, manufactured and serviced by one company

With Volvo Penta you need just one point of contact for the complete IPS package: engines, drives, propellers, instruments, accessories, service, warranties etc.

## Perfect propulsion package

Thanks to the unique marine torque, excellent fuel efficiency, first-class maneuverability, and reduced environmental impact, the Volvo Penta IPS meets the demands for any of your high-performance commercial applications. Each IPS installation is a complete and perfectly matched propulsion package – delivering optimum performance in all conditions.

## Forward-facing propellers work more efficiently

With IPS, the propellers work in undisturbed water. All power drives the boat forward and the propeller thrust is parallel with the hull. Forward-facing propellers also mean that all exhaust fumes are emitted through the pods and dispersed well behind the boat. And with the propellers positioned well beneath the keel line, air intrusion – and cavitation – is stopped.

- Forward-facing efficiency
- Virtually no fumes
- Cavitation-free



## The benefits\* of Volvo Penta IPS

- 40% longer cruising range
- 20% higher top speed
- 30% reduced fuel consumption
- 30% less CO<sub>2</sub> emissions
- 50% lower perceived noise level
- Safe and predictable handling
- Joystick

\* Compared with inboard shafts at cruising with planing hulls, approximate figures.

## Type approved by DNV

The Volvo Penta IPS system is covered by type approval for the engine, IPS drive and EVC system in accordance with DNV's rules for High Speed & Light Craft, based on SOLAS High Speed code. The Volvo Penta IPS 900 can also be supplied with a product certificate covering the complete system, from helm station to propeller, for vessels requiring fully classified machinery in accordance with DNV's High Speed & Light Craft rules.

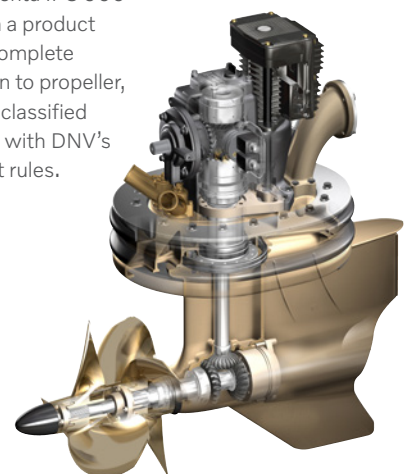



# The world's leading sterndrive

The Aquamatic sterndrive offers a total solution for operators who want an optimal combination of high speed, acceleration, fuel efficiency and comfort in boats 20 to 45 feet. It's a perfectly matched package – from controls to engine, drive and propellers – available with a wide range of fuel-efficient and reliable diesel engines.



## Better grip in water

The counter-rotating propellers – the Duoprop – provide unequalled performance, responsive handling and excellent grip in the water. All propellers are perfectly matched to a specific drive and application.

## Improve performance with EVC

The EVC platform further improves the performance of your Aquamatic, with a range of features for easier handling, increased safety and improved vessel control.

## Simple and efficient handling

The sterndrive range is available with smooth shift resulting in great maneuverability and comfort. The installation can also be delivered with an EVC joystick steering system for an even simpler handling.

## The benefits of Aquamatic sterndrive

- Low fuel consumption
- Low CO<sub>2</sub> emissions
- Low noise and vibrations
- Joystick





## A matching range



### The D3 series

This 5-cylinder D3 is extremely lightweight and compact. With features such as common rail fuel injection system, variable geometry turbocharger, and EVC, it offers world-class diesel performance and low emissions.



### The D4 series

From the latest design in modern diesel technology, this in-line 4-cylinder, 3.7-liter diesel engine features common-rail fuel injection, double overhead camshafts and turbo. It provides high reliability, exceptional fuel efficiency and low maintenance cost.



### The D6 series

This in-line 6-cylinder, 5.5-liter diesel engine is designed from the latest design in modern diesel technology. It features common-rail fuel injection, double overhead camshafts and turbo. It provides high reliability, exceptional fuel efficiency and low maintenance cost.



### The D8 series

Inline 6-cylinder engine with a twin-entry turbocharger and common rail fuel injection system. High low-end torque and wide rpm range make for unique maneuverability and acceleration. Low fuel consumption, low noise levels.



### The D11 series

This extremely powerful and compact 6-cylinder D11 engine features a unique twin-entry turbo that facilitates magnificent torque for powerful acceleration. This strong and highly efficient engine offers excellent reliability and long action range.



### The D13 series

As a smooth-running engine, the in-line, 6-cylinder D13 combines world-class diesel performance with low fuel consumption and emissions. This engine offers features such as a high-pressure unit injector system, "twin entry" turbo, aftercooler and EVC.



### The D16 series

The in-line, 6-cylinder D16 diesel features a robust block with ladder frame, "twin entry" turbo and charge-air cooler. The heat exchanger combined with the injection system and the engine management system further improves performance and drivability.

# A variety of applications

Volvo Penta type-approved engines together with the EVC or MCC system can be used for any high-performance propulsion system arrangement or requirement.

### FPP

The excellent load-carrying capability of the Volvo Penta engines makes them a perfect match for fixed-pitch propeller applications. A range of transmissions is available for different speeds and duty profiles.

### Waterjet

Volvo Penta engines are a perfect match for any type of waterjet, in terms of power/rpm range as well as engine response time.

### CPP

With our high-performance engines, controllable pitch can easily be optimized for different operating conditions, such as transit mode and cruise. Volvo Penta solutions are easily integrated with different transmissions and control systems.

### Surface drives

Thanks to their unique marine torque, Volvo Penta engines are an ideal power source for demanding surface drive applications.





**VOLVO  
PENTA**

[www.volvopenta.com](http://www.volvopenta.com)